



Delta 1st

T650C

Set Up Guide



Introduction



Let's get started! At Woodforest Acceptance Solutions, we aren't just here to process your transactions, we are on a mission to elevate your business and grow with you. Refer to this guide for detailed instructions on how to set up your new T650C device and start taking payments today!

Need help setting up? Our dedicated support team is here to help you every step of the way. Contact us any time at (888) 584-2265 with questions or expert assistance in activating your device.

Overview

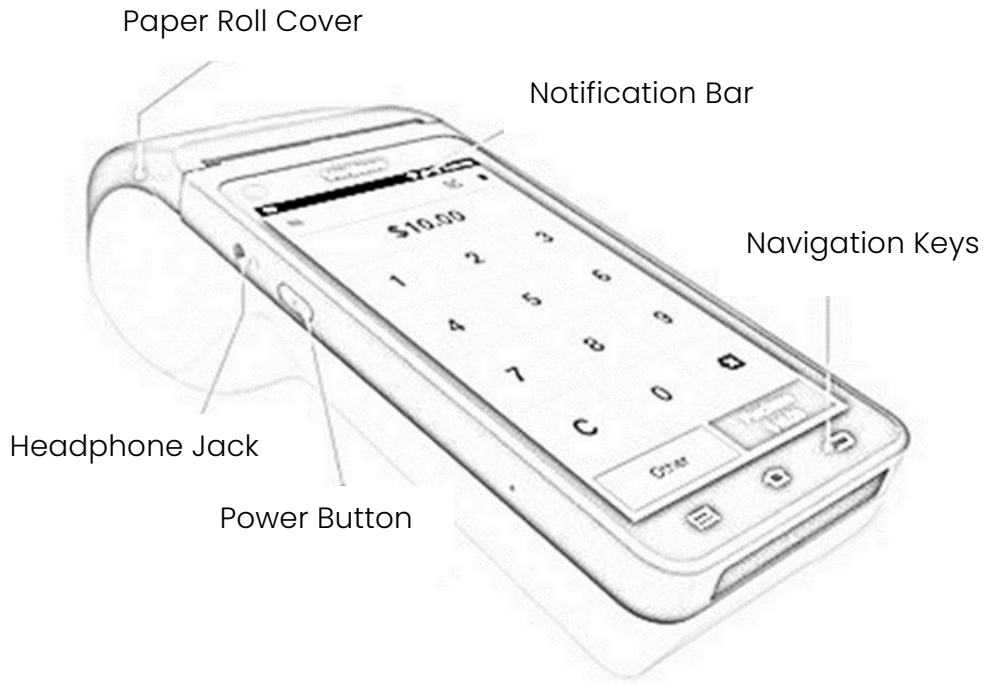

Figure 1



Steps to Follow to Assemble Completed Set Up (Figure 1):

1 - Unbox
Equipment

2 - Set Up
Payment Device

3 - Set up Delta1st
Software on
Payment Device

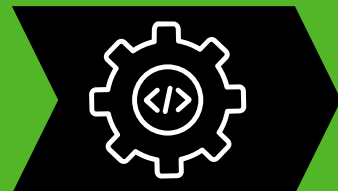

1. Unbox Equipment

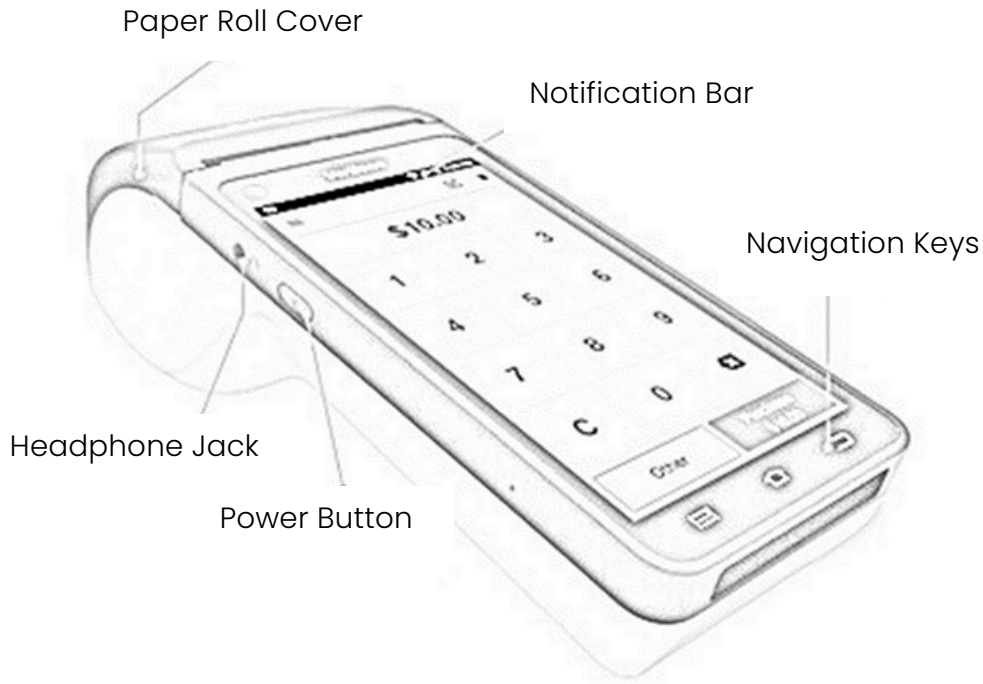

Figure 2



A. Remove Payment Device from box

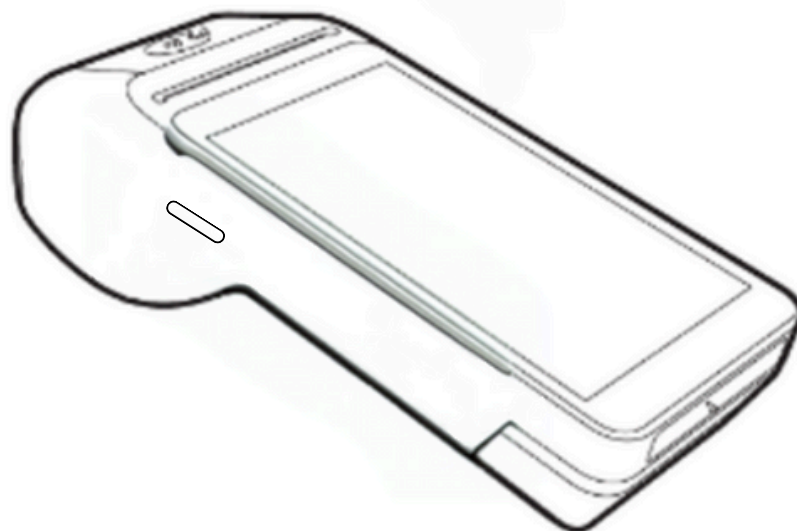
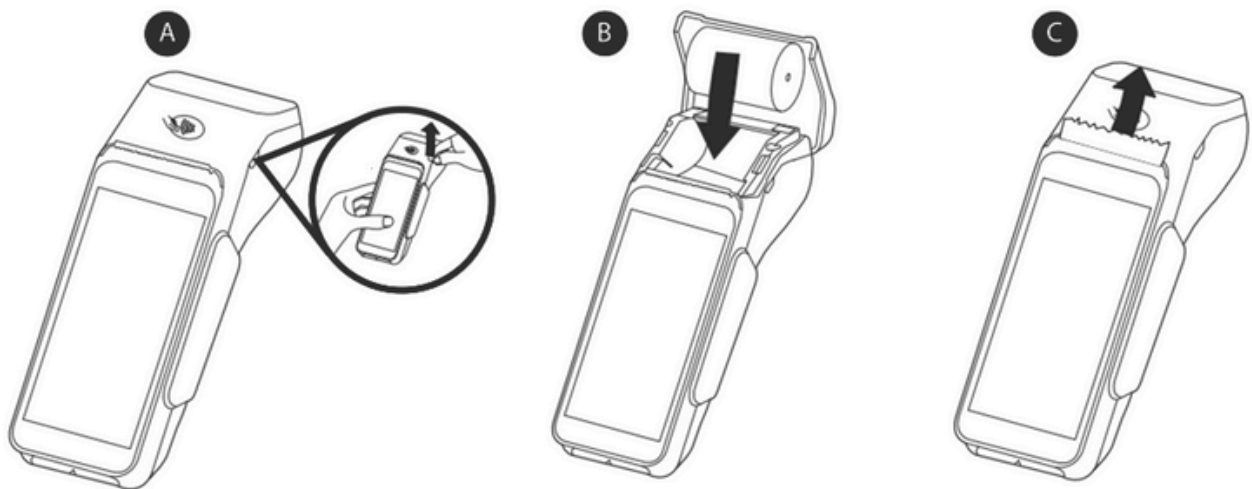

Figure 3



B. Load Paper in Payment Device

1. Open the paper door by pressing the sides inward then lifting up (Figure 4).
2. Place the paper roll inside. Make sure the paper is coming from underneath the roll, not over the top.
3. With the printer paper extending past the door, close the printer by pushing it down until it clicks shut, allowing the paper to extend.



*Printer paper is 2.25 in x 54 ft thermal paper.

Figure 4



C. Power on the Payment Device

1. Remove the back cover of the payment device by pushing down on the rectangular button and sliding the back cover off (Figure 5).
2. Plug the power cord into the far-left port on the inside of the payment device (Figure 6).

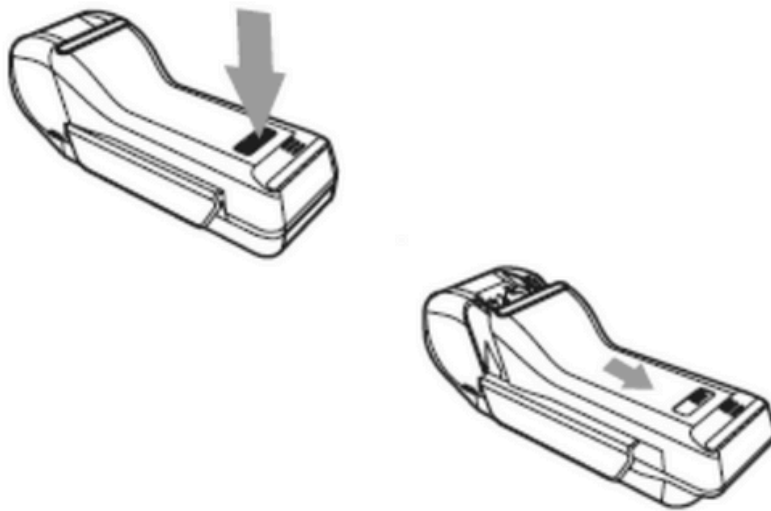

Figure 5

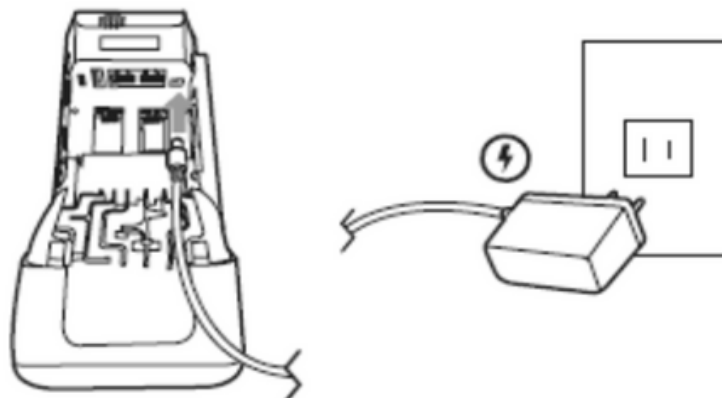

Figure 6



D. Power on the Payment Device

1. Feed the wire through the top and place the back cover back of the device (Figure 7).
2. Hold down the power button on the left-hand side of the payment device for three seconds.

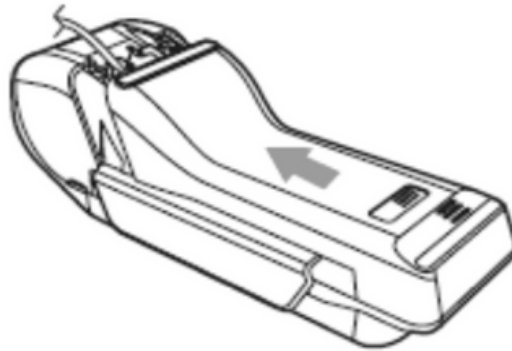

Figure 7

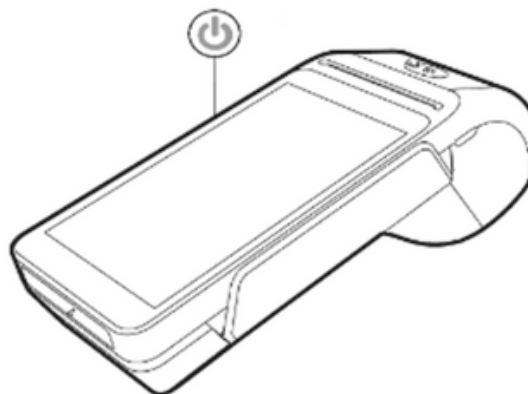

Figure 8

2. Set Up Payment Device



A. Activate Device and Adjust Settings

1. Select your preferred language.
2. Select your Wi-Fi network and enter in your Wi-Fi password. If using an ethernet cable, select 'Skip' during this step and plug the ethernet cable into port labeled ETH on the back of the device.
3. Enter the Device ID.
 - a. You can find the Device ID in your email from Verifone or on the packing slip attached to the box. To locate it, remove the packing slip from the plastic wrap and look at the bottom left under 'Remarks' for a 16-digit number. This is your Device ID.
 - b. After entering the Device ID, the device will begin a series of downloads, which can take up to 30 minutes. Please ensure the device remains on and connected to the internet until the process is complete.

3. Set Up Delta1st Software



A. Get Logged In

1. Check your inbox for an email titled "Your Delta1st Point of Sale Site is ready for use!" This email contains your URL and your login credentials.
2. On the payment device, enter your subdomain.
3. Enter the username and password to log in.

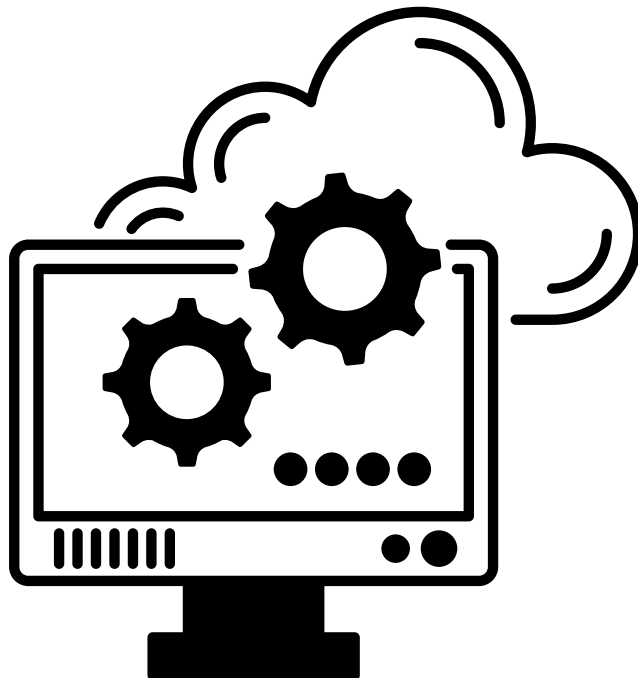

Begin Processing!



If the above steps are followed correctly, the T650C device should be ready to use. We strongly encourage you to run a test sale to ensure that the device is functioning properly.

For additional support with your setup, or with any other questions you may have during our partnership, please contact Woodforest Acceptance Solutions Support at (888) 584-2265 and select Option 2, or merchantsupport@woodforestpay.com.

Enjoy a modernized solution to not only generate revenue but also manage your business efficiently!